

INPUT LIST

#	SOURCE		notes
1	Cara Vocal		supplied SM 86
2	Hugh Vocal		supplied SM 58
3	Cara Guitar	DI	
4	Cara Mandolin	DI	
5	Hugh Bass	DI	no comp
6	Hugh Mando/ Steel	DI	
	All instruments are muted from stage		

Cara Luft

and Hugh McMillan

Stage Plot and Input List

DOWNSTAGE

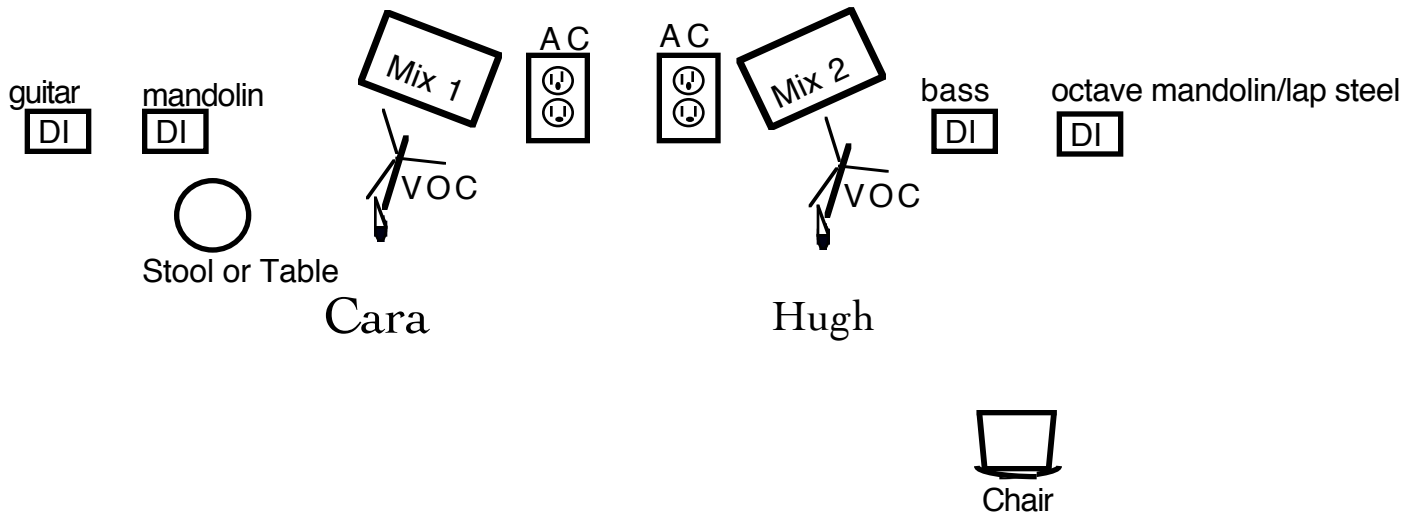

Mix Notes:

Cara Vocal - clear and present at all times, lyrics clearly audible.
 Cara Guitars - warm, big tone.

Hugh Bass - equiv. level to guitar (solos), no high pass, typical EQ: -3dB 80Hz, +1.5dB 300Hz, no compression, no high pass
 Hugh Mando/steel - typical EQ: - 3dB 1000Hz, +2dB hi shelf (2k5)

Please do not "ride" faders during performance